

scooterhelp.com

# LAMBRETTA Cento 100, J125, & J125 Starstream without battery

----- (WHITE)

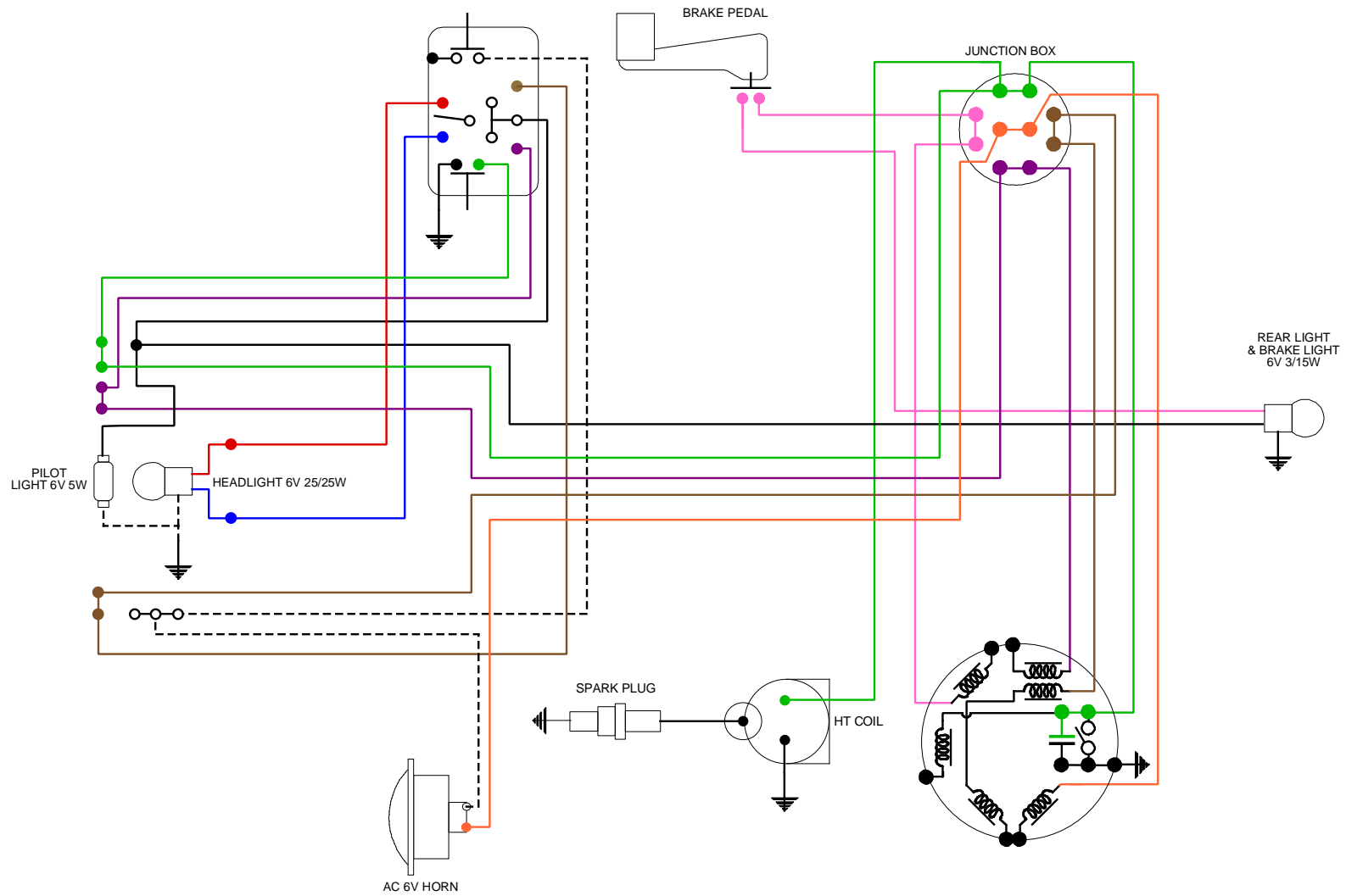

scooterhelp.com

LAMBRETTA Vega 75 S & Cometa 75 SL (Lui)  
without battery

----- (WHITE)



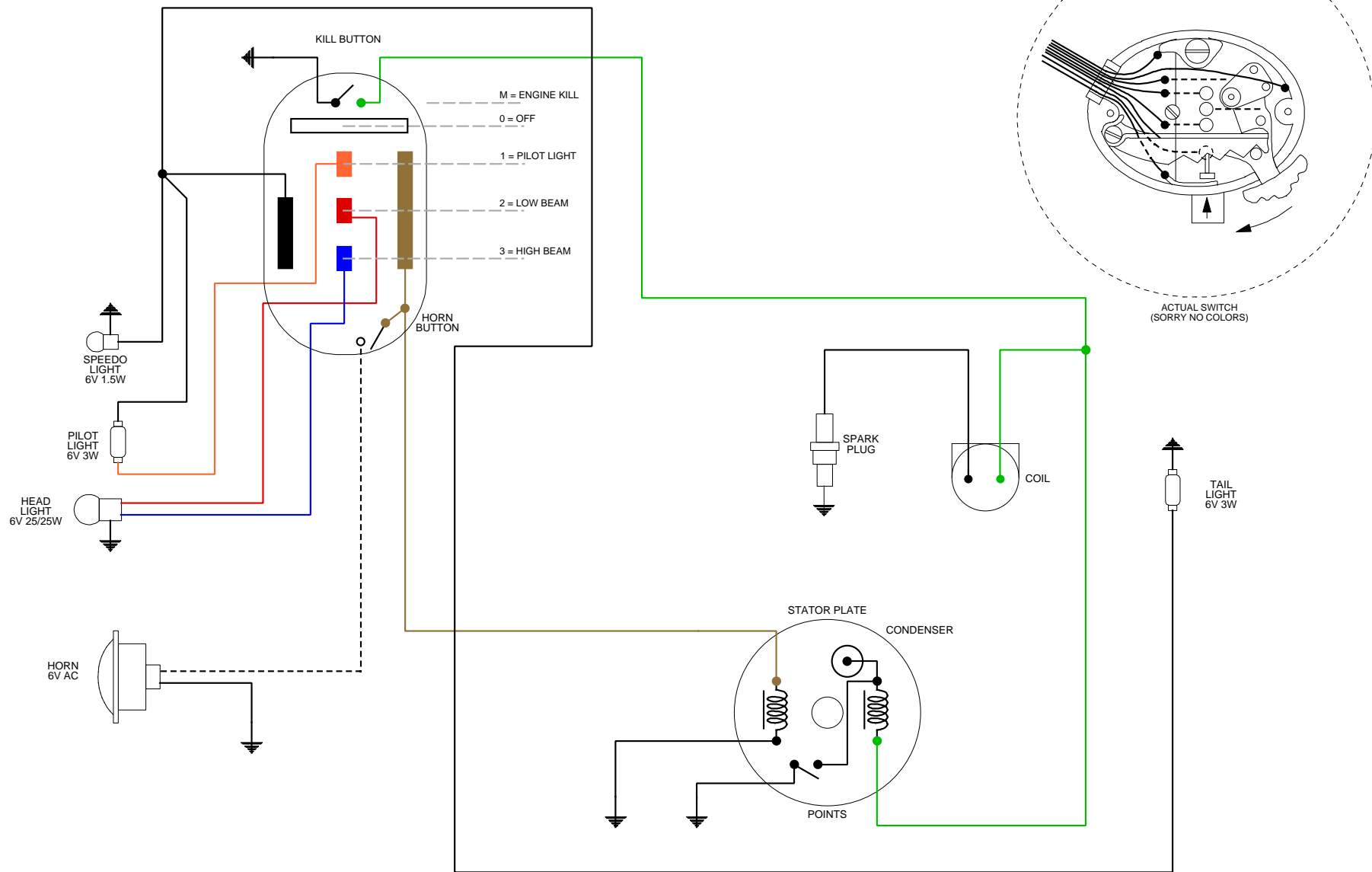

scooterhelp.com

LAMBRETTA LD 125 Series I, II & III  
LD150 Series I, II, III

----- (WHITE)

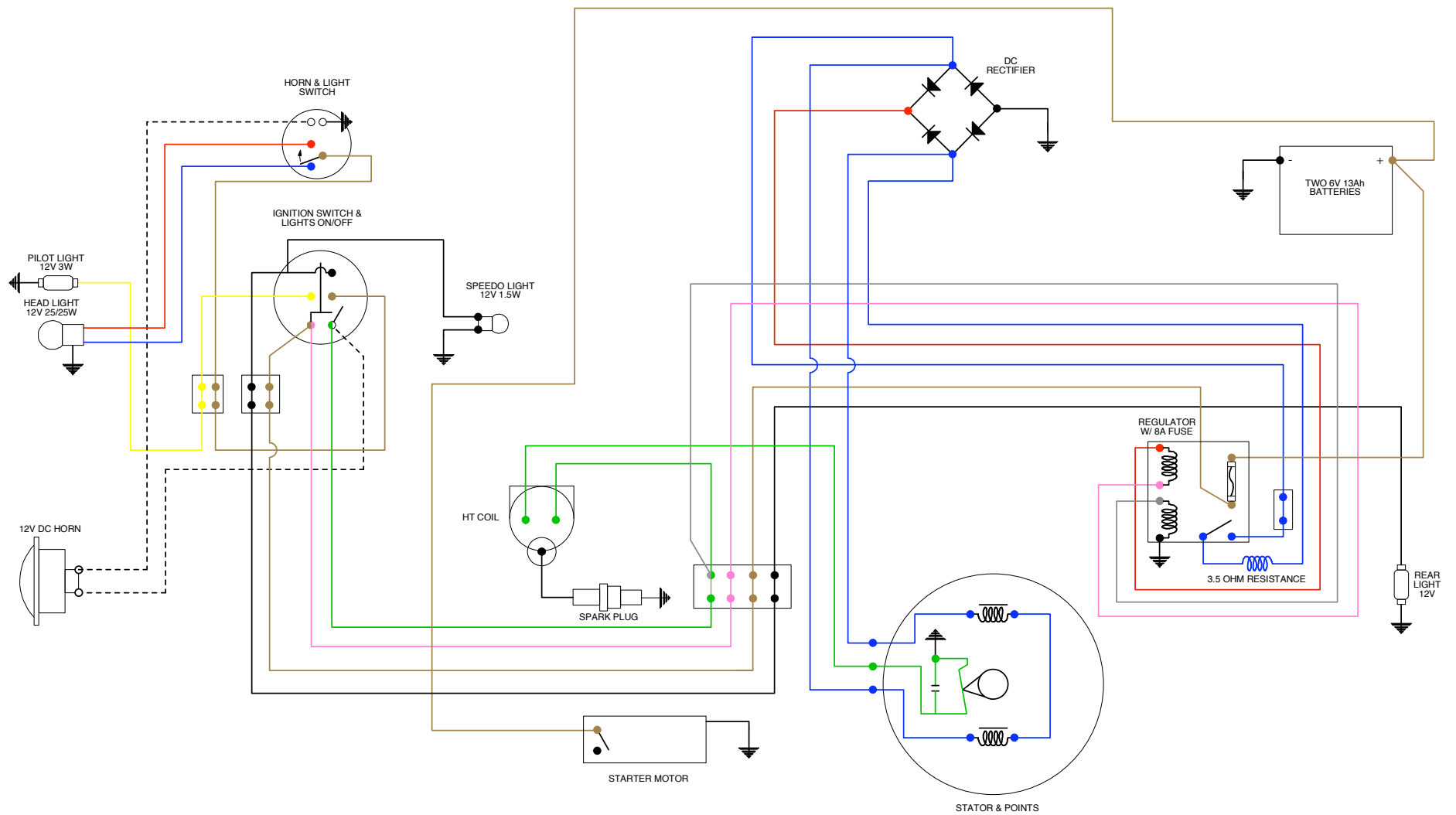

scooterhelp.com

### LAMBRETTA 150 LDA Mk 1-3 electric start

----- (WHITE)

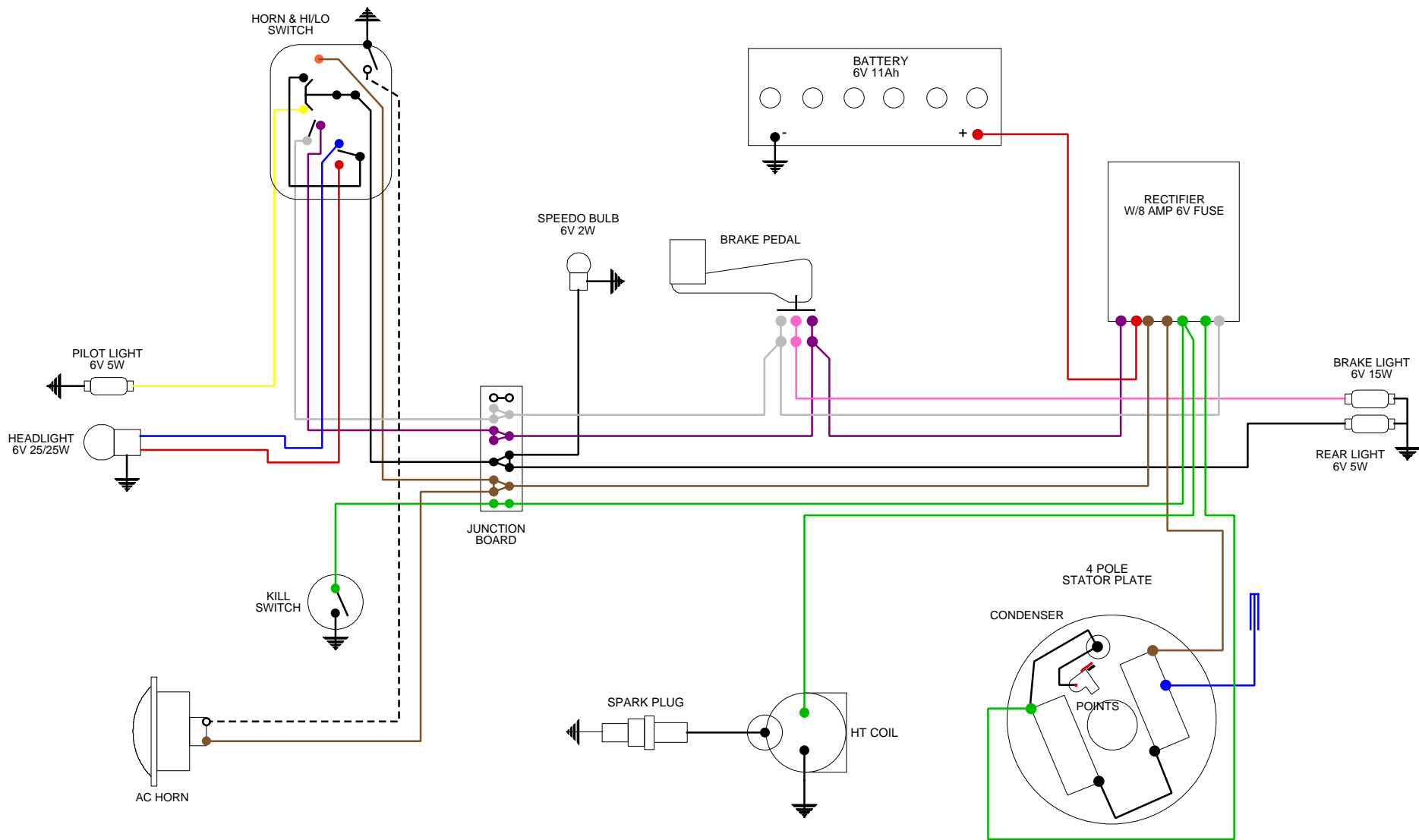

scooterhelp.com

LAMBRETTA Li125 & Li150 Series 1 and 2  
with 4 pole stator plate and battery

----- (WHITE)

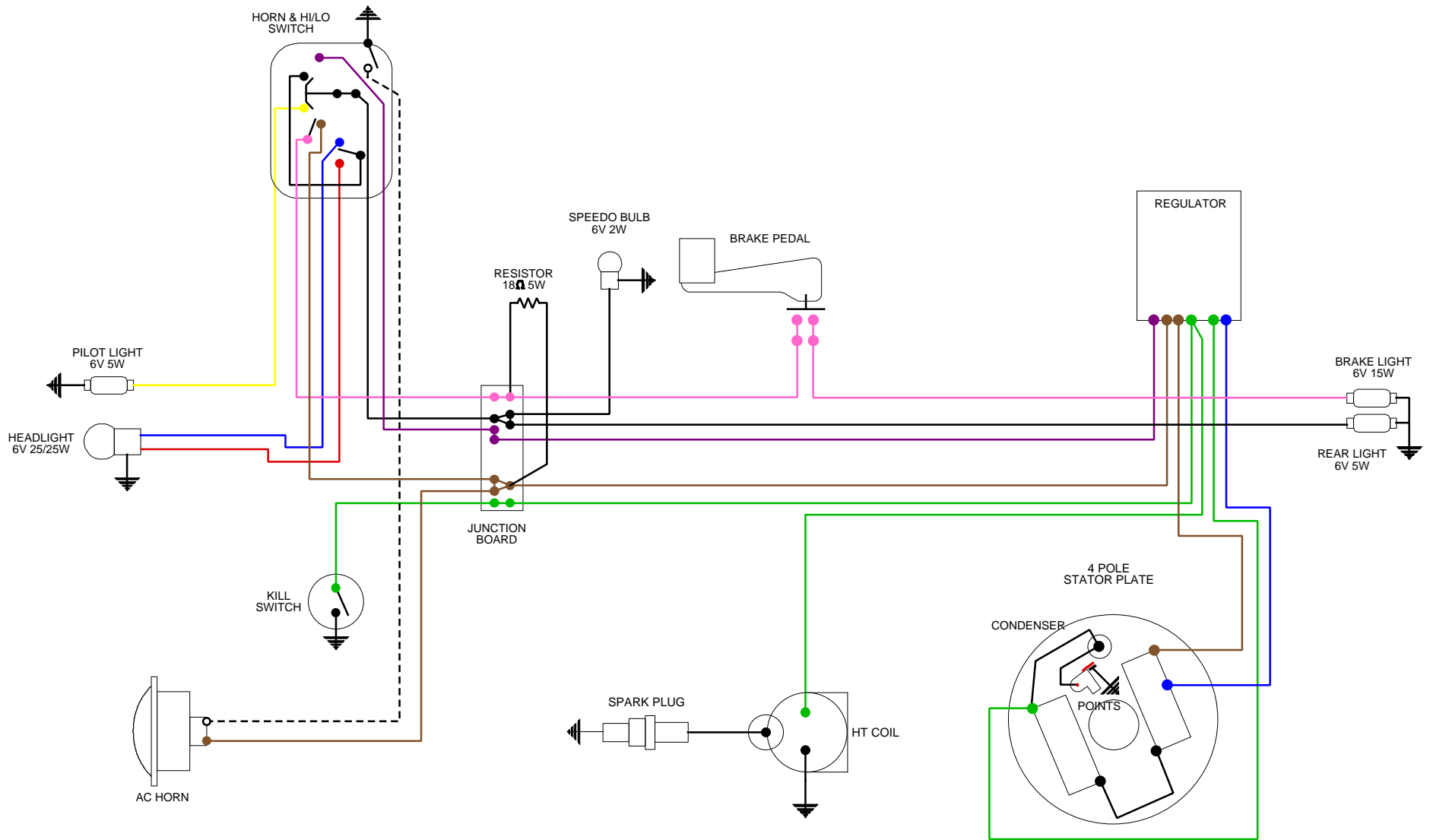

scooterhelp.com

# LAMBRETTA Li125 & Li150 Series 1 with 4 pole stator plate without battery

----- (WHITE)

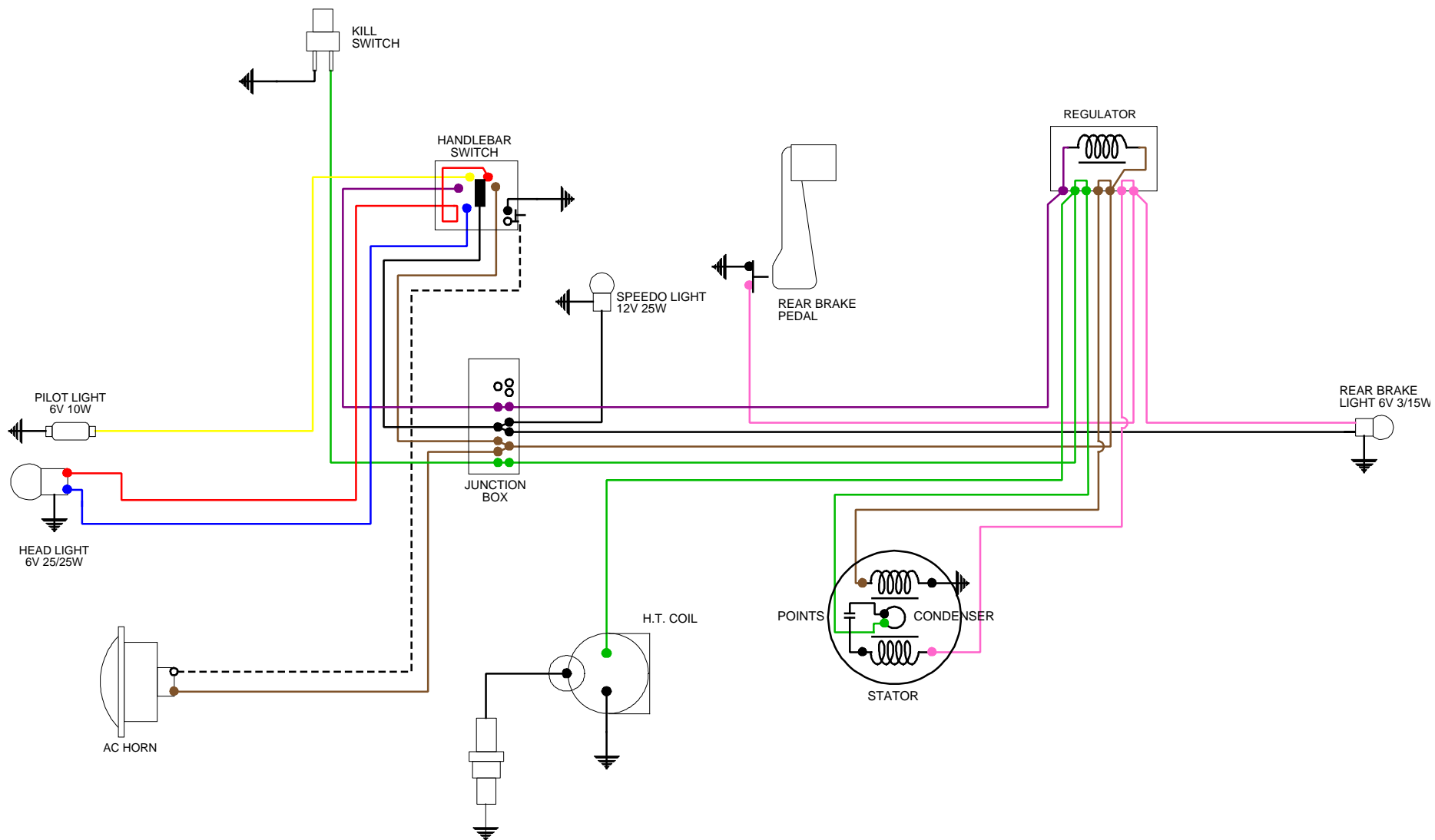

scooterhelp.com

LAMBRETTA Li125 & Li150 Series 2  
with 4 pole stator plate without battery

----- (WHITE)

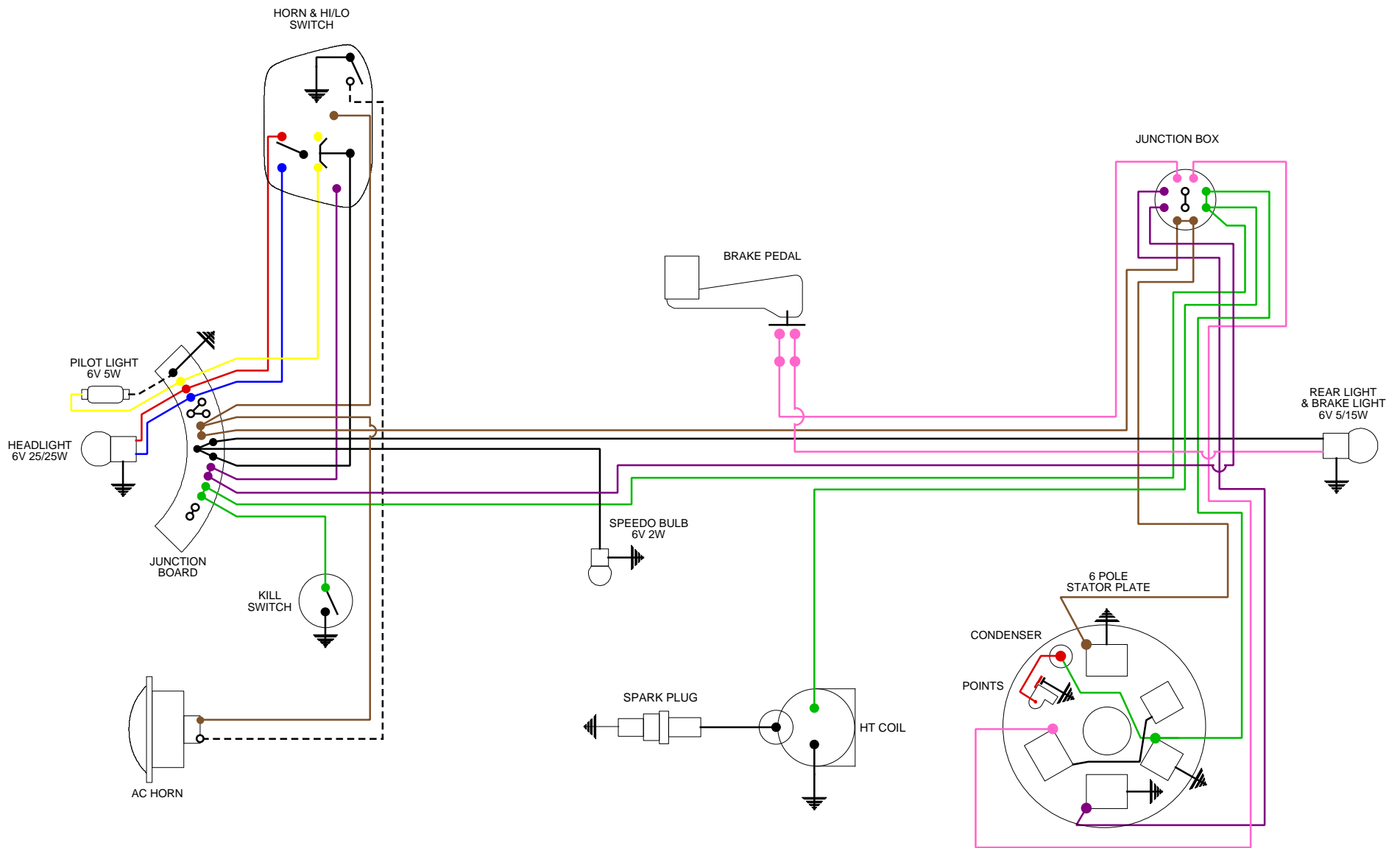

scooterhelp.com

# LAMBRETTA Li125 & Li150 Series 3 with 6 pole stator plate without battery

----- (WHITE)

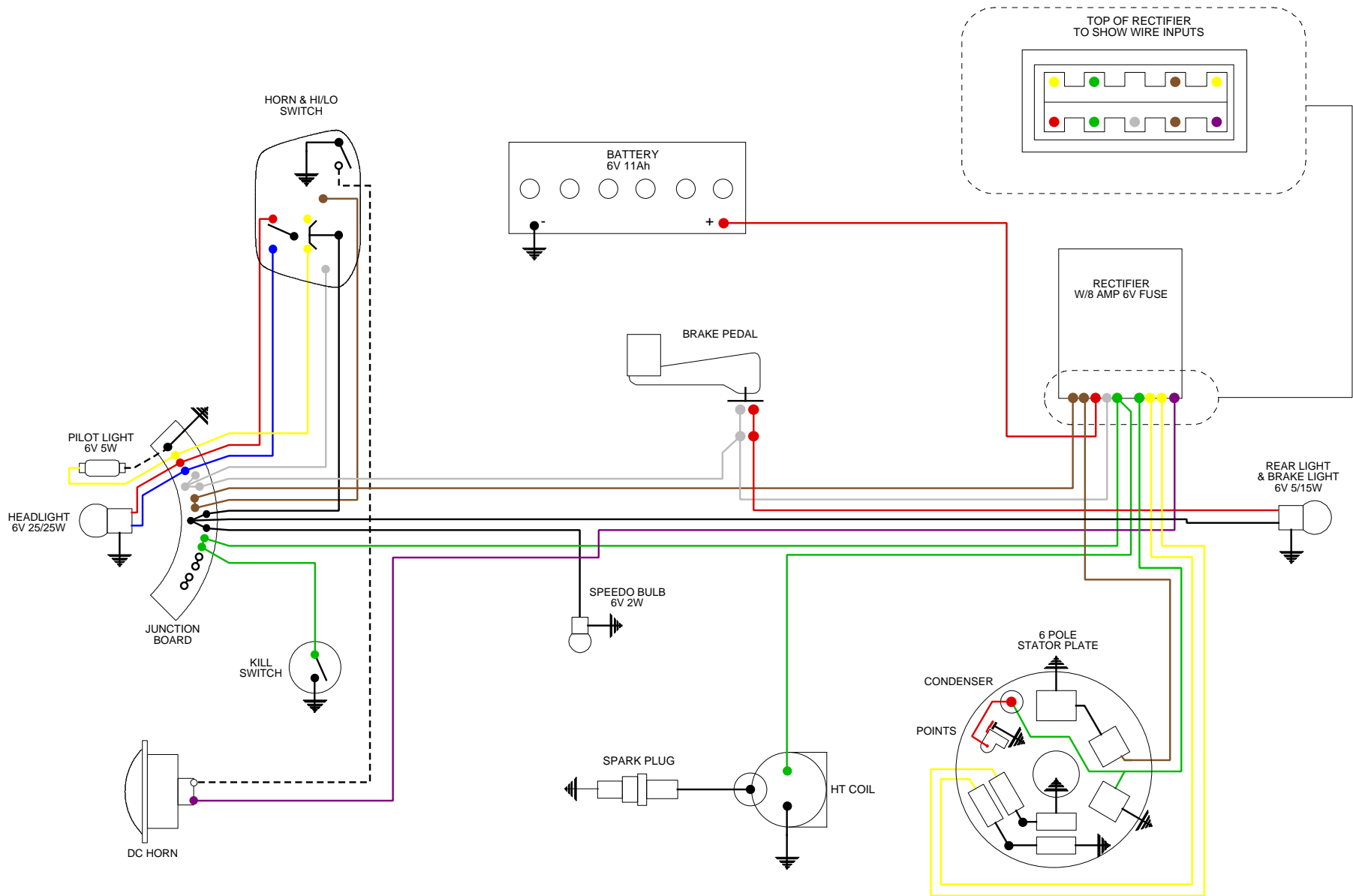

scooterhelp.com

### LAMBRETTA Li125 & Li150 Series 3 with 6 pole stator plate & battery

----- (WHITE)

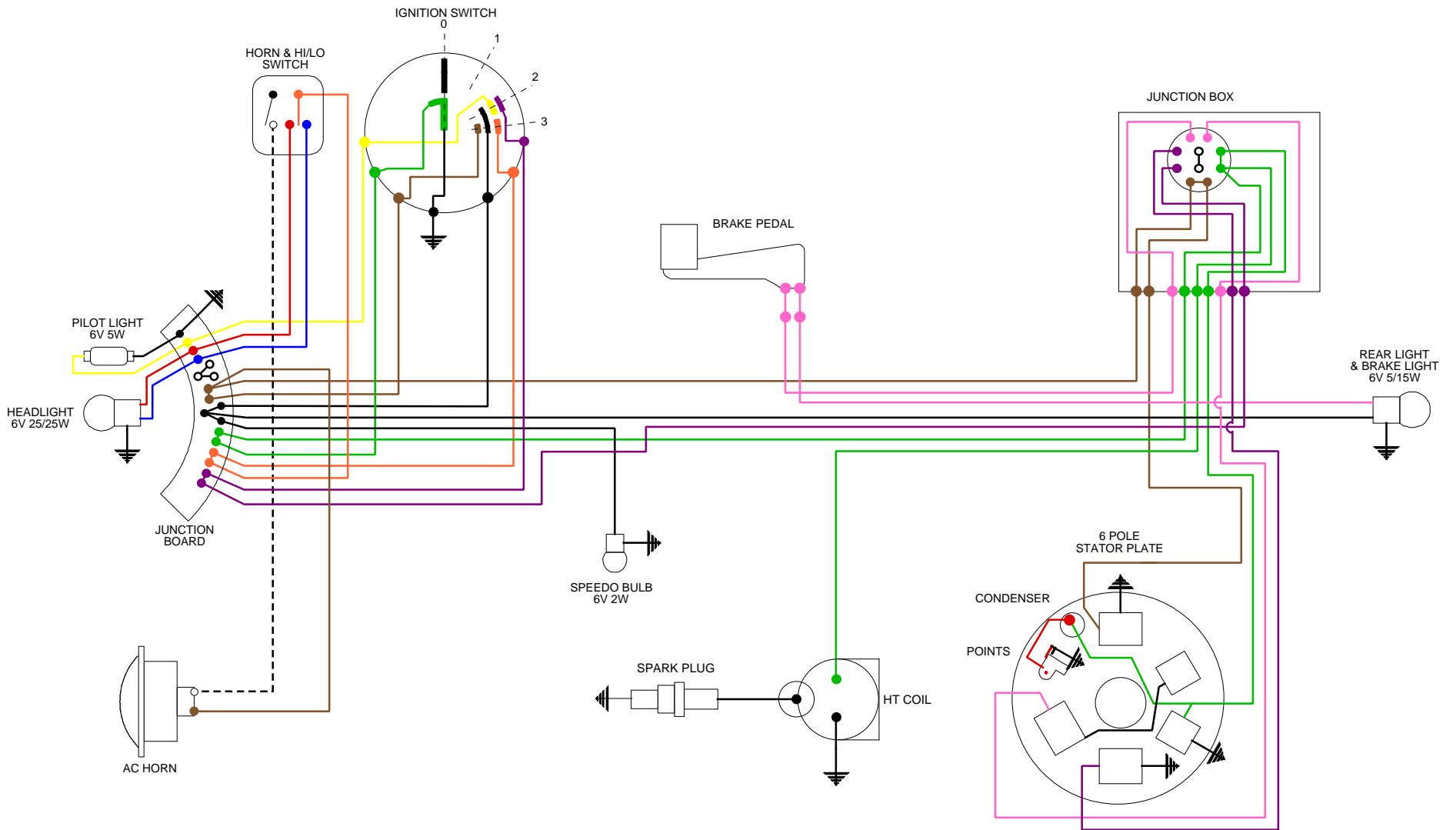

scooterhelp.com

# LAMBRETTA Li150S - SX150 - GP125 without battery

----- (WHITE)

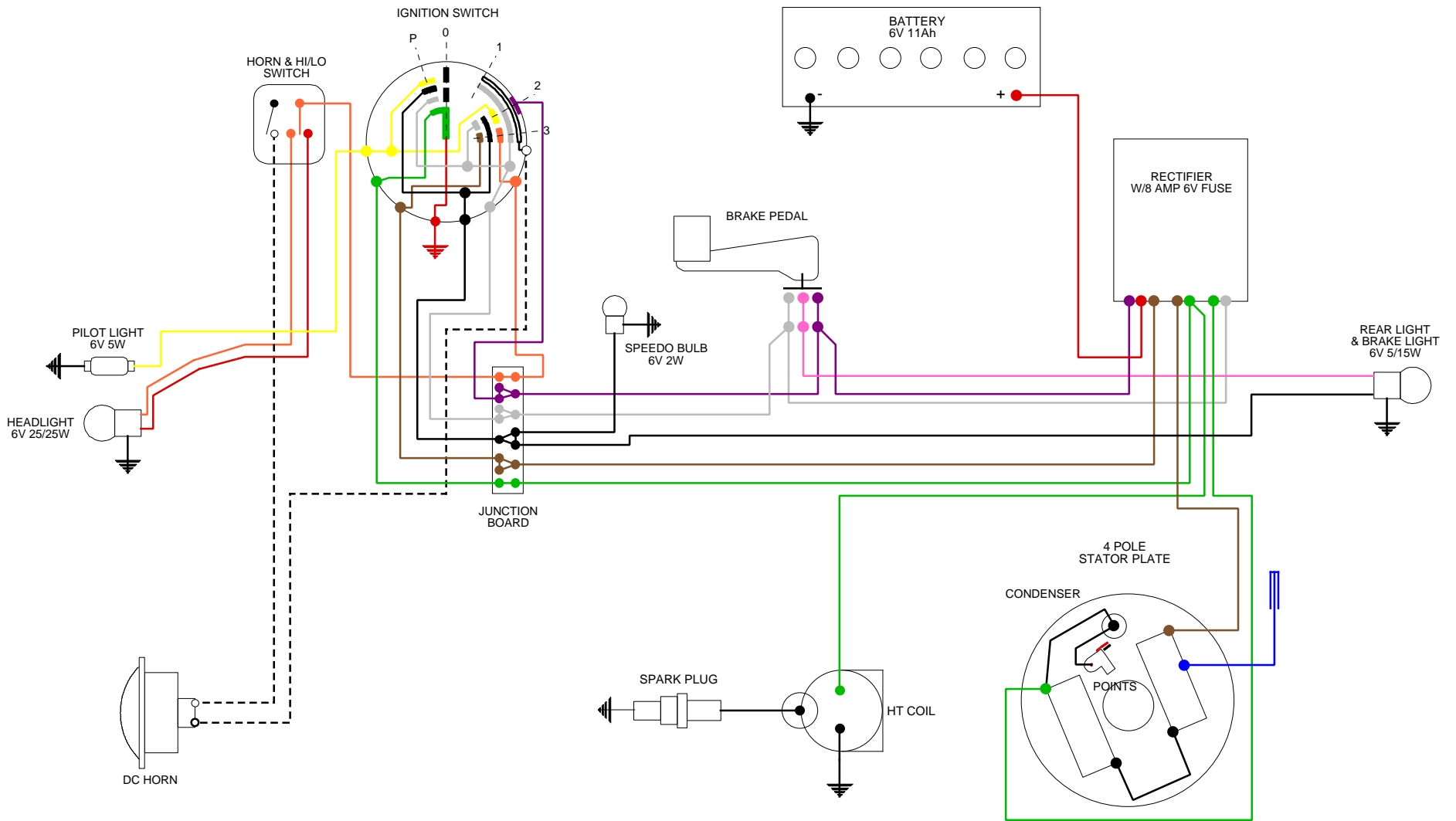

scooterhelp.com

# LAMBRETTA TV175 Series 2 and 3 with 4 pole stator plate & battery

----- (WHITE)

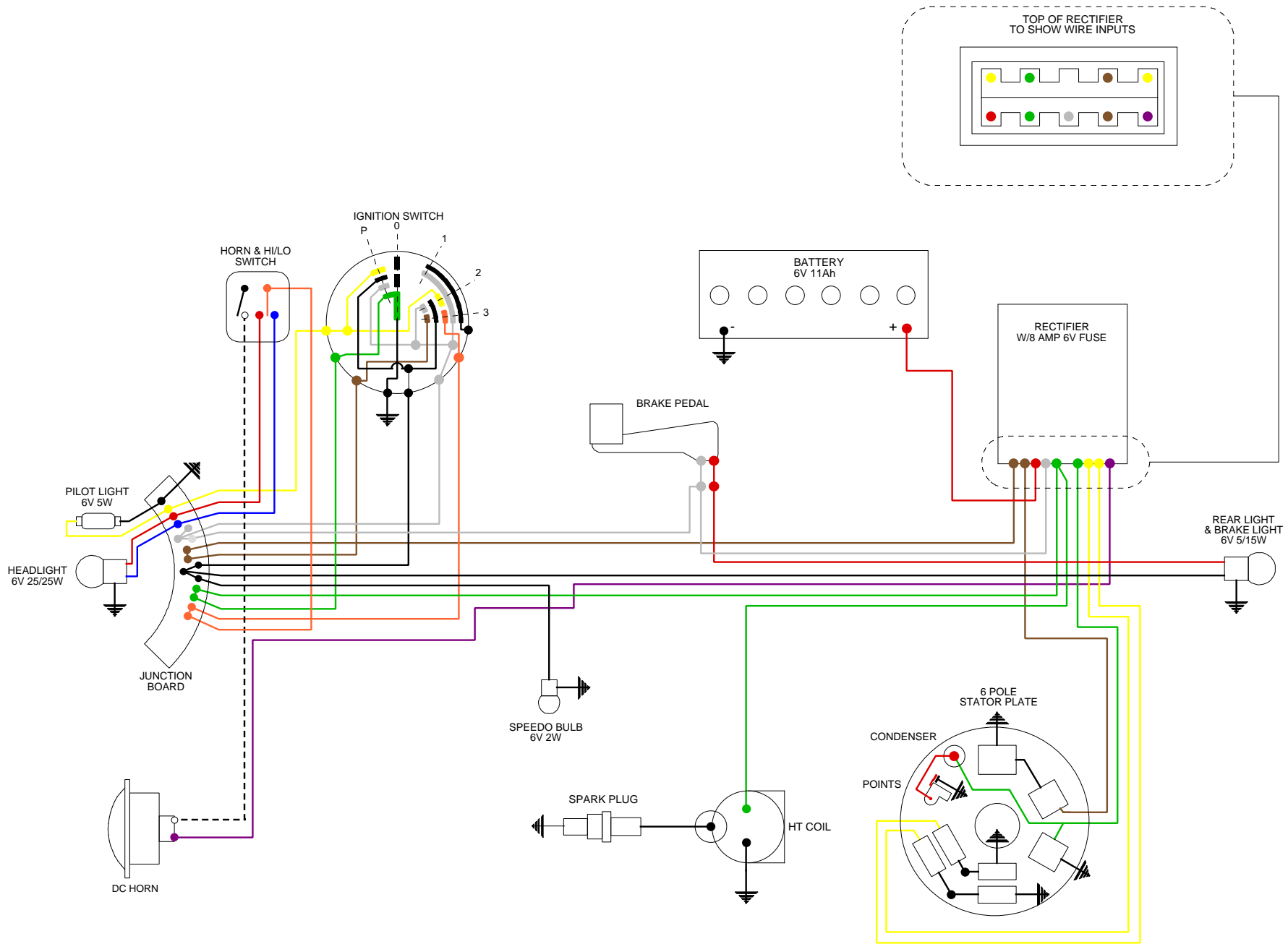

scooterhelp.com

LAMBRETTA TV175 Series 3 - Li150S - SX150 - GP150  
 TV200 (GT200) - SX200 - GP200

----- (WHITE)

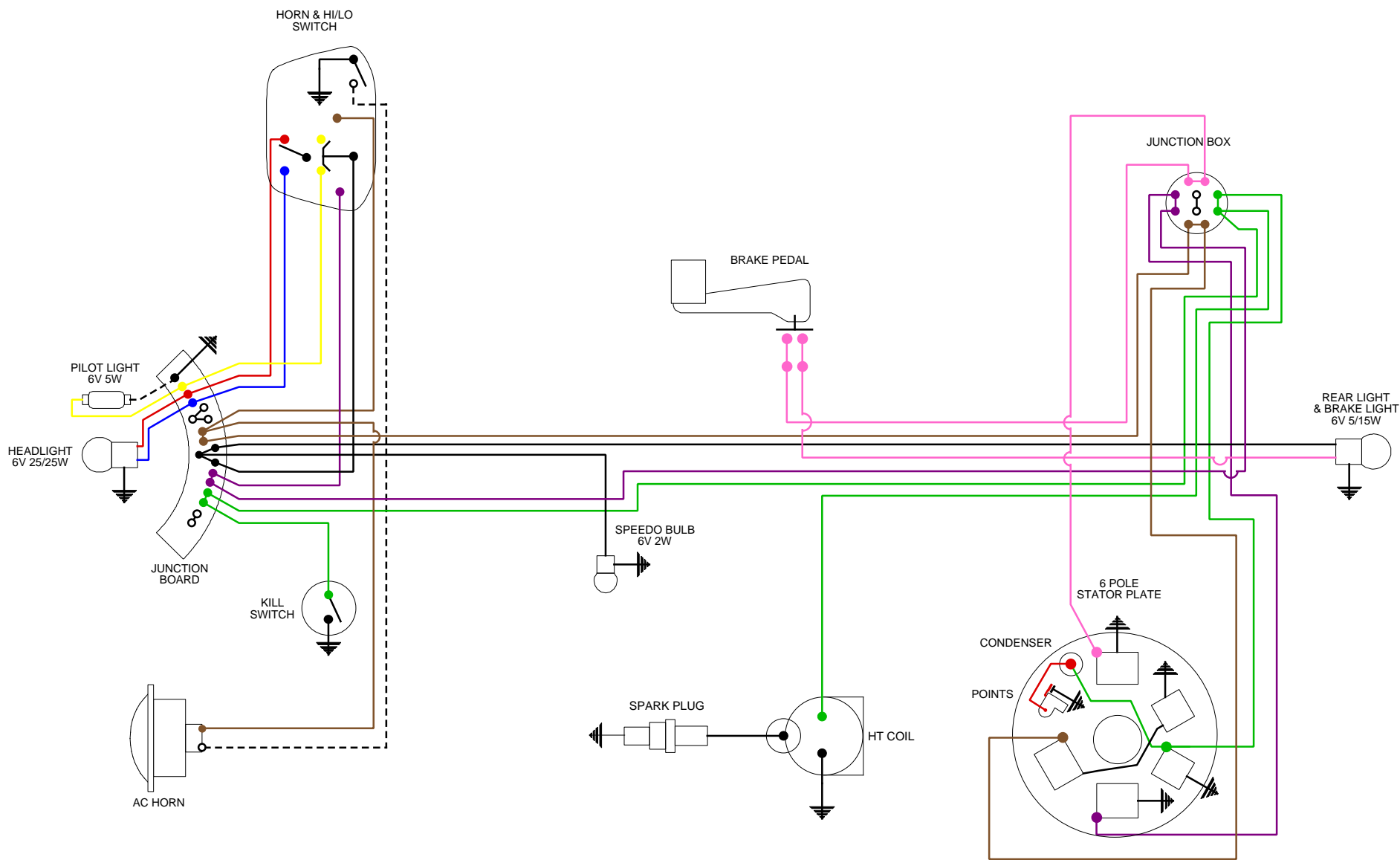

scooterhelp.com

# SPANISH LAMBRETTA Li125 & Li150 Series 3 & JET 200 with 6 pole stator plate without battery

----- (WHITE)